

NATURAL GAS FIRED EM50 HNG

SPECIFICATION DATASHEET

Energy Efficiency:	A++
Operational mode:	Mains parallel operation
Fuel:	Natural gas & H ₂ * ready
Electrical output (P_{el}):	50kW(e) ²⁾ min 25 kW
Thermal output (P_{th}):	90.1 kW ²⁾ min 57 kW
Fuel consumption:	139.2 kW ¹⁾ (nett) 154.5 kW
CHP coefficient:	(gross) 0.55
Efficiency:	EN50645
Total efficiency:	100.8% (nett) 90.8% (gross)
Electric efficiency:	35.9% (nett) 32.4% (gross)
Thermal efficiency:	64.9% (nett) 58.4% (gross)
Gas-connection pressure:	20-50 mbar
Gas-flow pressure:	≤16 mbar
Flow rate with natural gas:	14.5 Nm ³ /h
Flow temperature:	max. 90 °C
Return temperature:	max. 70 °C
Max. system pressure:	6 bar (heating side)
Supply air volume flow:	min. 600 m ³ /h
(Exhaust air volume flow:	min. 450 m ³ /h)
Ambient temperature:	5°C to max. 35°C
Exhaust gas emissions:	at 0 Vol% remaining oxygen
CO (carbon monoxide):	< 47.6 mg/kWh
NO _x (nitrogen oxide):	< 35.4 mg/kWh
Exhaust gas temperature:	Max 130 °C
Exhaust gas volume flow:	~ 225 m ³ /h
Exhaust gas mass flow dry:	~ 241 kg/h
Exhaust gas back pressure after CS ⁴⁾ :	max. 5 mbar
Sound pressure level CHP:	~ 54.8 dB(A) (1 m distance)

CHP: Dimensions, weights and connections

L x W x H CHP:	2.29 x 0.96 x 1.71 m (w/o handles, exhaust air opening)
Weight CHP: incl. oil and water:	2020 kg
Ø x HCS⁴⁾	0.41 x 1.88m (w/o flanges)
Weight CS	72 kg
Colour CHPP:	Pantone 5517C
Heating connections (VL):	R 1 1/4" Flow (warm) R 1 1/4" Return (cold)
Exhaust gas connection CS⁴⁾:	DN120
Gas connection:	R 1"

Motor

Motor	HMG 434/S
Type:	Straight line
Operation:	4-stroke
Cylinder:	4
Displacement:	4.9 litres
Nominal engine speed:	1500 1/min



Output curve [kW_{th} to kW_{el}]
Continuous modulation range

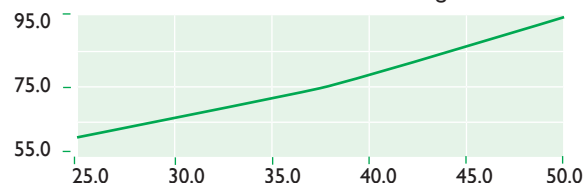

Consumption curve [Nm³/h to kW_{el}]

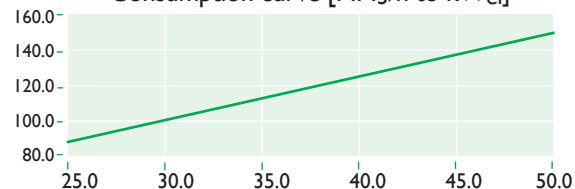

Efficiency curve [% to kW_{el}]

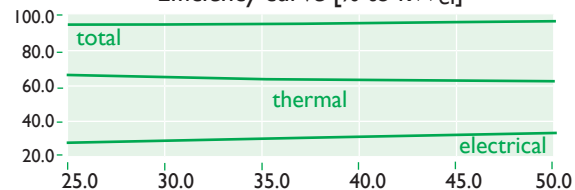

Sound pressure level curve [dB(A) to Hz]⁵⁾

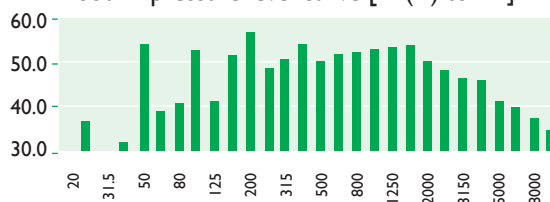

¹⁾ According to DIN ISO 3046-1, tolerance 5%

²⁾ Return temperature 60°C

³⁾ According to EU RL 2004/8/EG with 100% internal use

⁴⁾ Combination silencer

⁵⁾ Test stand measuring without liability

⁶⁾ According to EnEVAndV 2009



PRIME MOVER UNIT

ASYNCHRONOUS GENERATOR EMOD WKASYG

Cooling:	water cooled
Power:	53 kW
Voltage:	400 V
Nominal current:	88 A
Frequency:	50 Hz

ELECTRICAL DATA ENERGIMIZER 50H

Max. effective power P_{Amax} :	50 kW
Max apparent power S_{Amax} :	52 kVA
cos:	0.97
Nominal voltage U_N :	400 V
Rated current I_r :	75 A
Grid input:	three phase current
Isolated operation intended?:	No
Motor-driven start intended:	No
Starting current I_A :	-
Short circuit current $I''K$:	0.91 kA
Short circuit stability of the complete system I_K :	10 kA
Reactive power compensation:	Existing
Number of compensation steps:	1
Reactive power per step:	25 kVARw
Detuning factor respectively resonance frequency:	0
Own requirement:	1.132 kW

SETTING GRID PROTECTION (VDE-AR-N 41050)

Voltage drop protection $U<$	0.8 U_n (100 ms)
Voltage increase protection $U>$	1.1 U_n (100 ms)
Voltage increase protection $U>>$	1.15 U_n (100 ms)
Frequency drop protection $f<$	47.5 Hz (100 ms)
Frequency increase protection $f>$	51.5 Hz (100 ms)

CABINET: DIMENSIONS AND WEIGHT

(Floor sited, connections at the bottom, standard cable set 6 m)	
W x D x H:	0.80 x 0.40 x 1.80 m
Weight:	220 kg
Colour:	Pantone 5517C

Standard reference conditions according to DIN ISO 3046-1: The technical data are based on natural gas H with a heating value of 10.0 kWh/Nm³ (total air pressure 100 kPa, air temperature 25°C, relative humidity 30%, 100m above sea level). Power adjustment at ambient conditions according to DIN ISO 3046-1 respectively DIN 6271-3. The tolerance of the specific fuel consumption is +5% at nominal power and the tolerance of the usable thermal output is 7% at nominal power. We reserve the right to change data and characteristics without prior notice in accordance with our business policy and the ongoing development process.

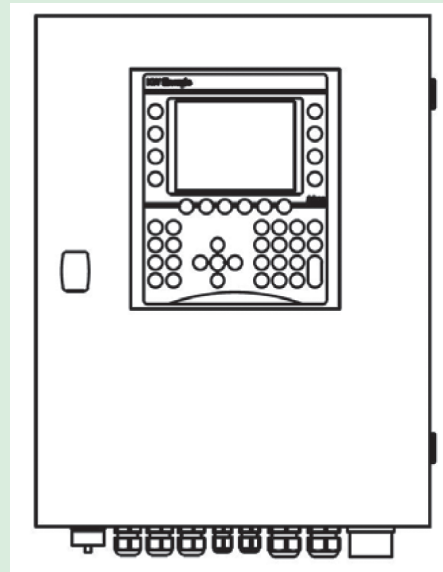

ENERGIMIZER 50H CONTROL BRI 8

Programmable BRI8 SPS control system to control , adjust , calculate , measure and display result . The control system is equipped with a full graphics display and all function buttons , required to operate the combined heat and power plant . The 5.7" LCD display shows information about the system and its current status

The BRI8 can optionally be expanded by a heating control system, requirement peak load boiler (up to 2 boilers), data transfer via LAN and Internet with an error notification via email (only with DSL) and an interface connection to external systems (Ethernet UDP, Mod-Bus RTU, RK 512, 3964R).

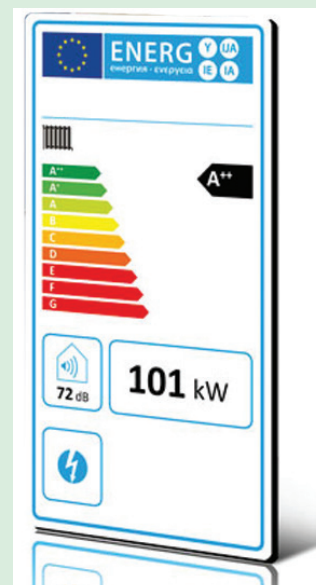

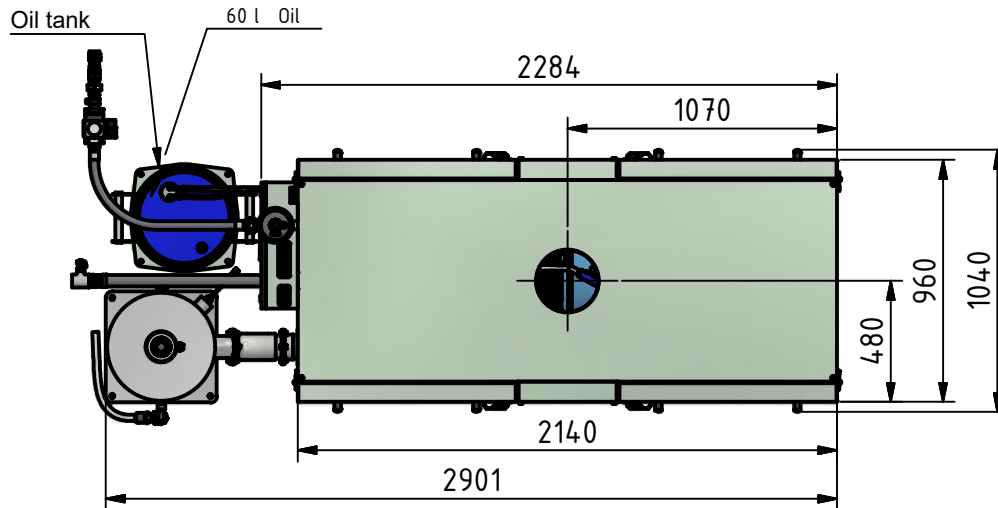
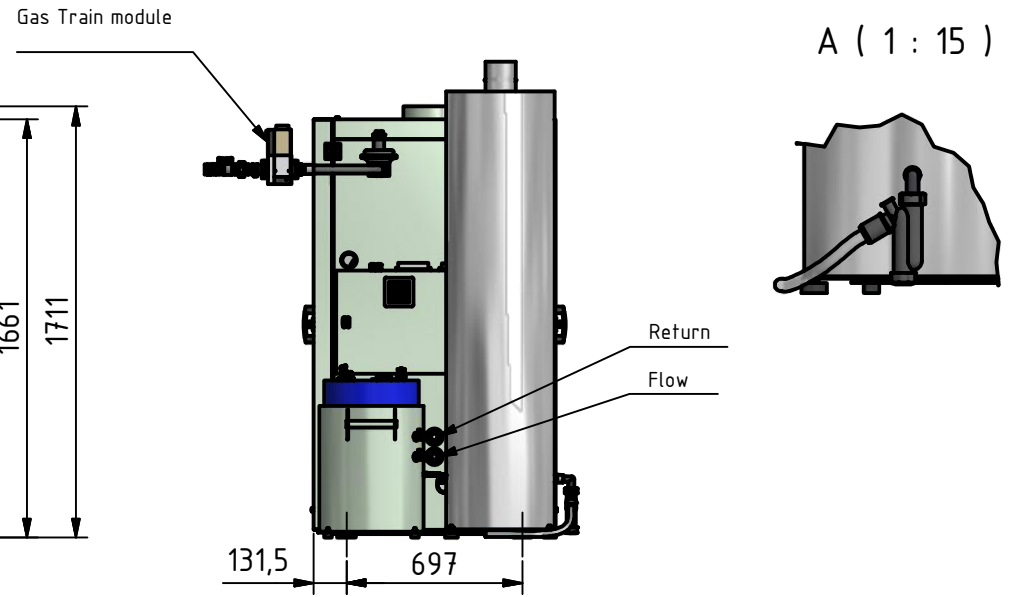
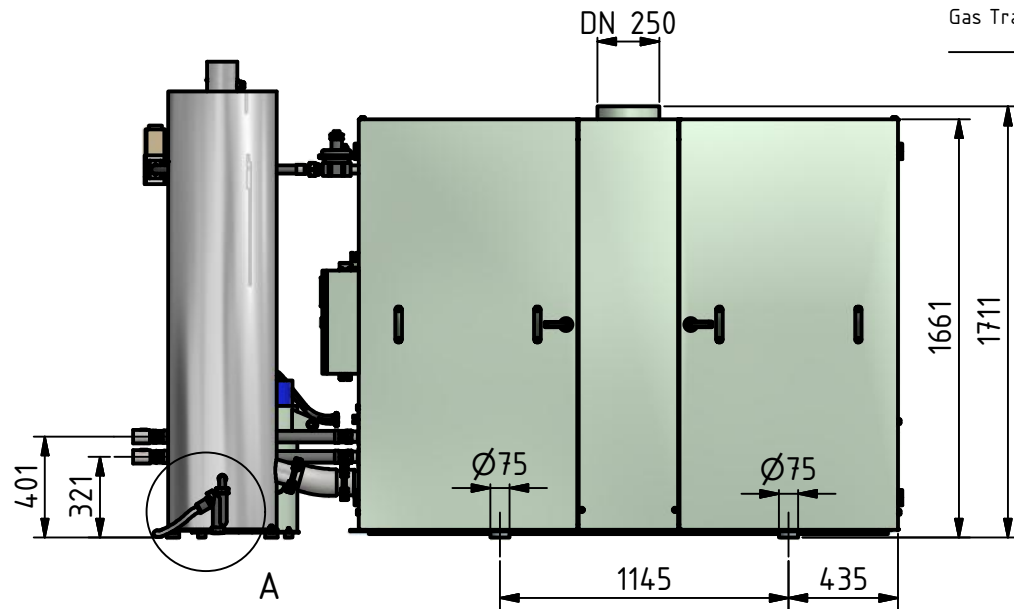

Notes on installation

At the place of installation, a distance of **800mm** must be freely accessible all around the CHP. In addition a minimum clearance height of **2500mm** above the installation site be made available and a level surface with sufficient load bearing capacity is required (Floating screed is not suitable)

If the minimum clearances are not observed, service and repair work can lead to increased costs due to difficult working conditions

		CHP Dimensions		Product code.		Allgemeintoleranz	
				EM50HNG		DIN ISO 2768-mK	
		Hinweis:		Datum	Freigabe / Name	Maßstab	Revision
CAD-Zeichung, alle Rechte vorbehalten, Schutzvermerk nach DIN ISO 16016		10.05.2016	A. Dünhuber	1:30	Blattgröße	Blatt	von
					A4	1	1