

# NATURAL GAS FIRED EM 33NG

## SPECIFICATION DATASHEET

Energy efficiency:	A++
Operational mode:	Mains parallel operation
Fuel:	Natural gas, LPG & H2*
Electrical output (P <sub>el</sub> ):	33kW(e) <sup>2)</sup> min 16.5 kW
Thermal output (P <sub>th</sub> ):	67 kW <sup>2)</sup> min 43.5 kW
Fuel consumption:	97.7 kW <sup>1)</sup> (nett) 109.2 kW
CHP coefficient:	(gross) 0.46
Efficiency:	EN50465
Total efficiency:	101.6% (nett) 91.5% (gross)
Electric efficiency:	33.5% (nett) 30.2% (gross)
Thermal efficiency:	68.1% (nett) 61.3% (gross)
Gas-connection pressure:	20-50 mbar
Gas-flow pressure:	≤16 mbar
Flow rate with natural gas:	9.9 Nm <sup>3</sup> /h
Flow temperature:	max. 90 °C
Return temperature:	max. 70 °C
Max. system pressure:	6 bar (heating side)
Combustion & cooling air requirement:	min. 125 m <sup>3</sup> /h (85 kg/h)
Ambient temperature:	5°C to max. 35°C
Exhaust gas emissions:	at 5 Vol% remaining oxygen
CO (carbon monoxide):	< 40 mg/m <sup>3</sup> (50% TA-air)
NOx (nitrogen oxide):	< 27.3 mg/m <sup>3</sup> (50% TA-air)
Exhaust gas temperature:	~ 50 °C <sup>2)</sup>
Exhaust gas volume flow:	~ 125 m <sup>3</sup> /h
Exhaust gas mass flow dry:	~ 135 kg/h
Exhaust gas back pressure after CS <sup>4)</sup> :	max. 5 mbar
Sound pressure level CHP:	~ 48.5 dB(A) (1 m distance)

### CHP: Dimensions, weights and connections

L x W x H CHP:	1.59 x 0.91 x 1.105 m
Weight CHP: incl. oil and water:	1080 kg
x H CS <sup>4)</sup> :	0.30 x 1.52 m (w/o flanges)
Weight CS <sup>4)</sup> :	30 kg
Colour CHPP:	Pantone 5517C
Heating connections (VL):	R 1" Flow (warm) R 1" Return (cold)
Exhaust gas connection CS <sup>4)</sup> :	DN100
Gas connection:	R 3/4" NG R 1/2" LPG

### Motor

Type:	K36
Operation:	Straight line
Cylinder:	4-stroke
Displacement:	4
Nominal engine speed:	3.6 litres
	1500 1/min



Output curve [kW<sub>th</sub> to kW<sub>el</sub>]  
Continuous modulation range

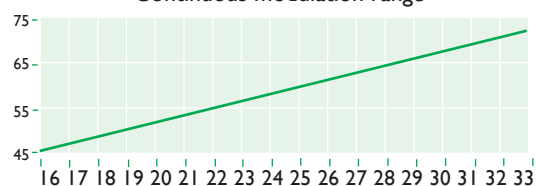

Consumption curve [NM<sup>3</sup>/h to kW<sub>el</sub>]

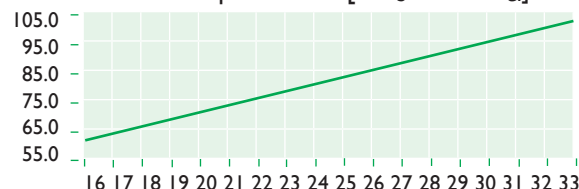

Efficiency curve [% to kW<sub>el</sub>]

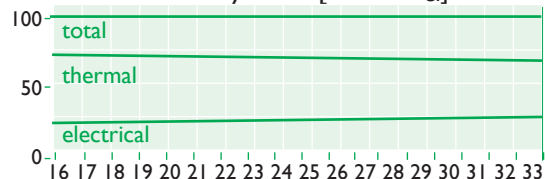

Sound pressure level curve [dB(A) to Hz]<sup>5)</sup>

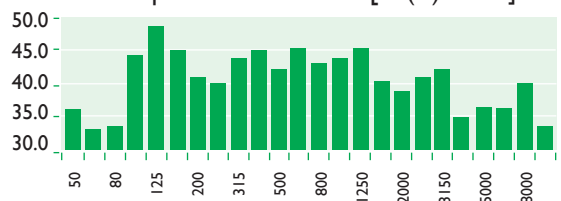

<sup>1)</sup> According to DIN ISO 3046-1, tolerance 5%

<sup>2)</sup> Return temperature 60°C

<sup>3)</sup> According to EU RL 2004/8/EG with 100% internal use

<sup>4)</sup> Combination silencer

<sup>5)</sup> Test stand measuring without liability

<sup>6)</sup> According to EnEVAndV 2009



## PRIME MOVER UNIT

### ASYNCHRONOUS GENERATOR EMOD WKASYG

Cooling:	water cooled
Power:	33 kW
Voltage:	400 V
Nominal current:	45 A
Frequency:	50 Hz
Operating mode:	S1

### ELECTRICAL DATA ENERGIMIZER EM33

Max. effective power $PA_{max}$ :	33 kW
Max apparent power $SA_{max}$ :	34 kVA
cos :	0.97
Nominal voltage $U_N$ :	400 V
Rated current $I_r$ :	45 A
Grid input:	three phase current
Isolated operation intended?:	No
Motor-driven start intended:	No
Starting current $I_A$ :	-
Short circuit current $I''_K$ :	0.25 kA
Short circuit stability of the complete system $I_K$ :	10 kA
Reactive power compensation:	Existing
Number of compensation steps:	1
Reactive power per step:	9.3 kVARw
Detuning factor respectively resonance frequency:	0
Own requirement:	0.055 kVA

### SETTING GRID PROTECTION (VDE-AR-N 41050)

Voltage drop protection $U <$	0.8 $U_n$ (100 ms)
Voltage increase protection $U >$	1.1 $U_n$ (100 ms)
Voltage increase protection $U >>$	1.15 $U_n$ (100 ms)
Frequency drop protection $f <$	47.5 Hz (100 ms)
Frequency increase protection $f >$	51.5 Hz (100 ms)

### CABINET: DIMENSIONS AND WEIGHT

(Wall mounting, connections at the bottom, standard cable set 6 m)	
W x D x H:	0.40 x 0.19 x 0.52 m
Weight:	21 kg
Colour:	Pantone 5517C

Standard reference conditions according to DIN ISO 3046-1: The technical data are based on natural gas H with a heating value of 10.0 kWh/Nm<sup>3</sup> (total air pressure 100 kPa, air temperature 25°C, relative humidity 30%, 100m above sea level). Power adjustment at ambient conditions according to DIN ISO 3046-1 respectively DIN 6271-3. The tolerance of the specific fuel consumption is +5% at nominal power and the tolerance of the usable thermal output is 7% at nominal power. We reserve the right to change data and characteristics without prior notice in accordance with our business policy and the ongoing development process.

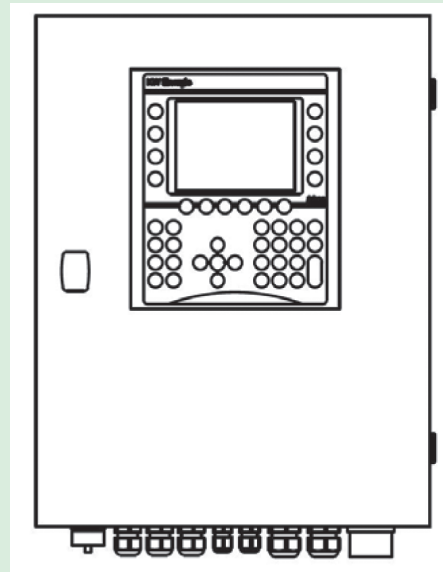

### ENERGIMIZER 33 CONTROL BR18

Programmable BR18 control system to control, adjust, calculate, measure and display outputs. The control system is equipped with a full graphics display and all function buttons, required to operate the combined heat and power plant. The 5.7" LCD display shows information about the system and its current status.

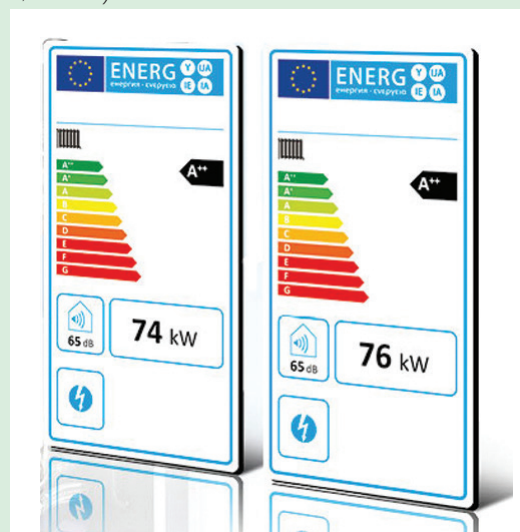

The BR18 can optionally be expanded by a heating control system, requirement peak load boiler (up to 2 boilers), data transfer via LAN and Internet with an error notification via email (only with DSL) and an interface connection to external systems (Ethernet UDP, Mod-Bus RTU, RK 512, 3964R).

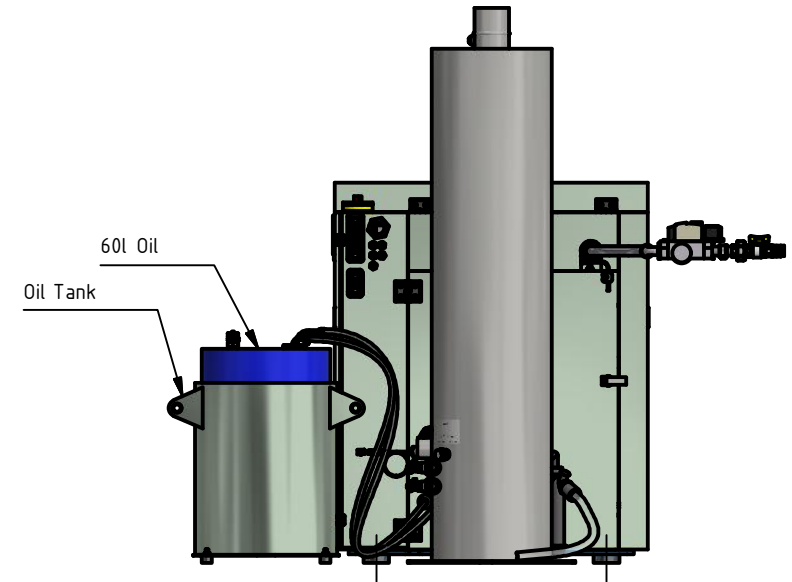
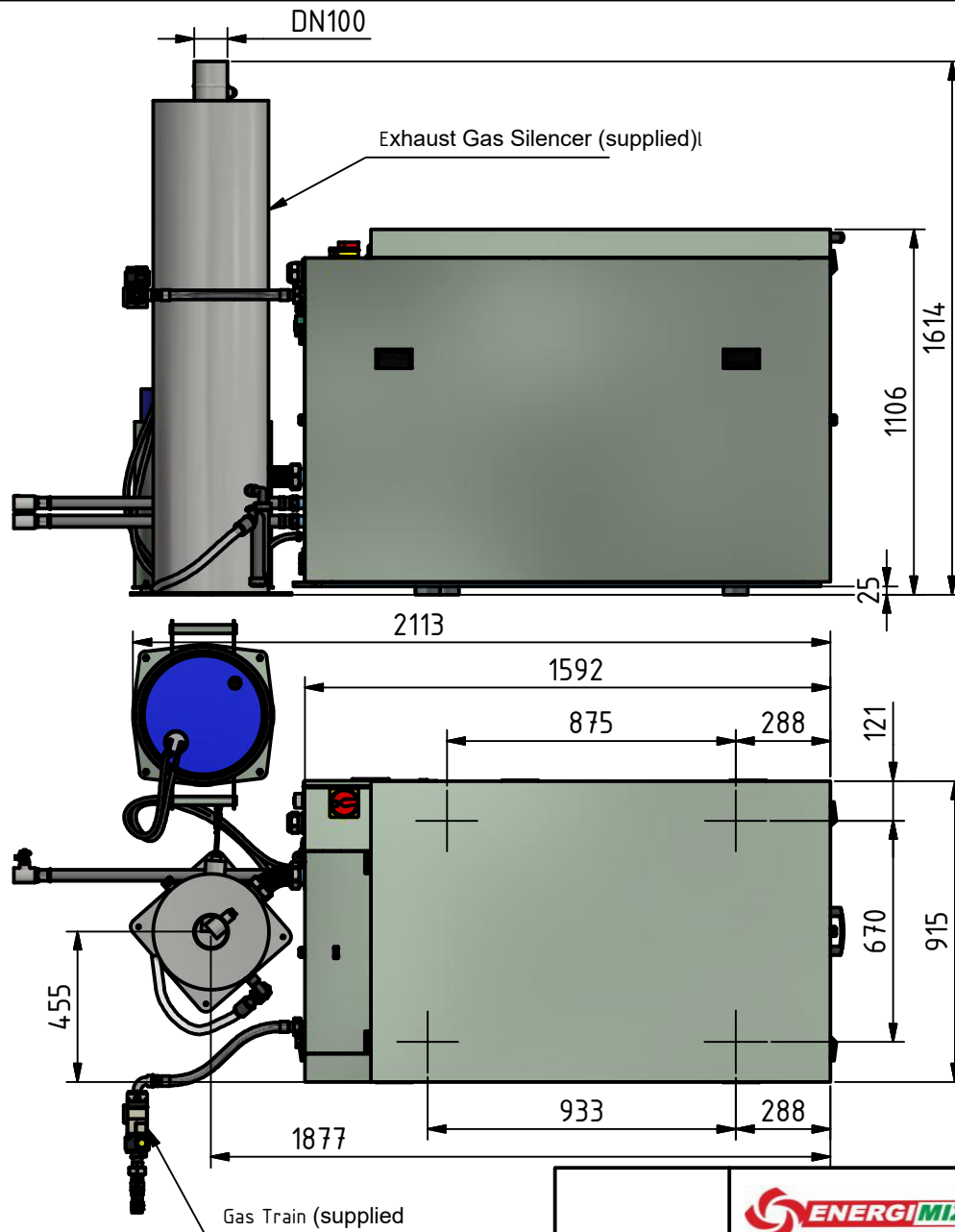



A maintenance & service area of at least **600mm** is required for access around both sides and the front section of the CHP canopy with at least 600mm be available above the CHP canopy.

With Non compliance this may negate the warranty and delay any fault rectification (if required)

	 <b>CHP Dimensions</b>		Product code. <b>EM33NG - SB33</b>		Allgemeintoleranz DIN ISO 2768-mK DIN ISO 1302 DIN ISO 13715		
	Werkstoff		Datum	Freigabe / Name		Maßstab	Revision
	Hinweis:		14.03.2018	A. Dünhuber		1:25	
	CAD-Zeichung, alle Rechte vorbehalten, Schutzvermerk nach DIN ISO 16016		Geprüft			Blattgröße	Blatt von
					A4	1 1	